

General information: Photometric calculation

1. STREETLIGHTING QUALITY CHARACTERISTICS

To calculate the quality characteristics, the light distribution of the luminaire is measured, i.e. the light intensity (cd/klm) is measured for a number of C and gamma angles.

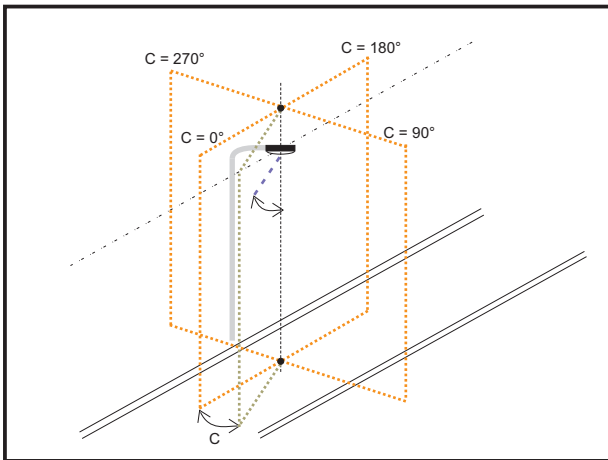

Then the illumination of a theoretical street, illuminated by 5 luminaires, is calculated.

For the area, between the second and third pole, the computer calculates, by means of the reflection properties of the road, how the incident flux is reflected in the direction of the driver, 60 m before the second pole in the middle of the drivinglane.

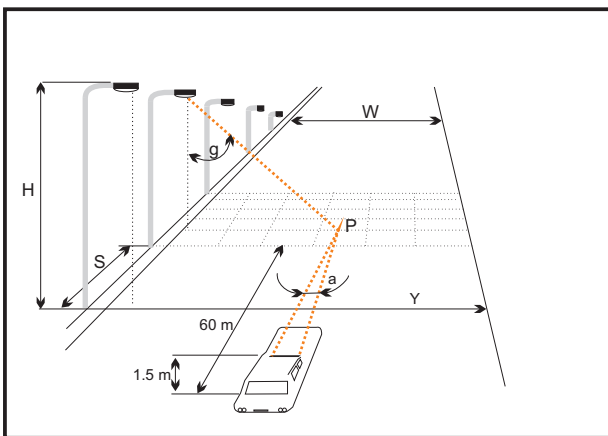

CIE specifies different roadsurfaces what reflection properties are concerned:

- R1 = DIFFUSE REFLECTION
- R2 = DIFFUSE-COMPOUND REFLECTION
- R3 = SPECULAR-COMPOUND REFLECTION
- R4 = SPECULAR REFLECTION

The result of the calculation is a table with the luminance value of a number of points on the street.

The quality of the streetlighting depends on:

- AVERAGE LUMINANCE
- LUMINANCE UNIFORMITY
- GLARE CONTROL

Values of average luminance and uniformity (ratio between minimum an mean or maximum luminance values) are deducted from luminance table.

Glare is evaluated by Treshold Increment (TI) and glare mark (G), which are calculated by means of empiric formulas.

Depending on the road category CIE recommends following values for the quality characteristics:

Road Classification		Quality characteristics			
Cat. of road	Type	Average Luminance (Cd/m ²) L_n	Overall Uniformity U_o	Longitudinal Uniformity U_i	Treshold Increment % TI
A	Motorway Express way	2	0.4	0.7	10
B	Trunk way Major way				
C	Ring road Radial road	1.5		0.5	15
D	Commercial road				
E	Local street Collector road	0.6		20	



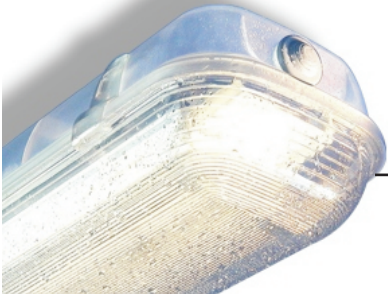

General information: Photometric calculation

2. ILLUMINATION CALCULATION FOR INTERIOR LIGHTING

Number of luminaires to create an average illumination level working plane on floor is:

$$N = \frac{E \times S}{U \times d \times n \times F}$$

E = average illumination level
 S = surface of working plane (on floor) in m²
 U = utilisation factor
 d = maintenance or depreciation factor
 n = number of lamps per luminaire
 F = luminous flux per lamp

To obtain an illuminance uniformity (E_{min}/E_{ave}) of at least 70% on the working plane, the luminaires must be positioned in a regular pattern on the ceiling.

The maximum center to center distance between two luminaires must be equal or less than "e".

For each luminaire the "e/h" ratio is found in the catalogue.

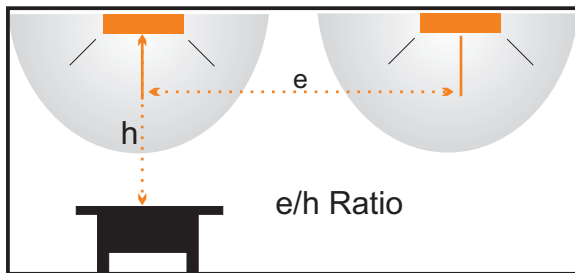

2.1. Average Illumination Level

Recommended illumination levels for office lighting:

1000 to 1600 Lux	Critical drawing tasks
400 to 800 Lux	General office work
200 to 400 Lux	Stores and stockrooms
100 to 200 Lux	Circulation areas

2.2 Working Plane

Working plane height: - 0.75 m for office
 - 0.85 m for working areas

2.3 Utilisation factors

Depends on luminaire type, luminaire wattage, room dimensions (room index) and reflectance of ceiling, walls and floor. Is found in datasheets as function of:

- Room index: $K = \frac{L \times B}{h \times (L + B)}$

L = length
 B = width
 h = distance luminaire - working plane

- Reflectance:

Colour	Average Reflectance
White	80 %
Light grey	50 %
Grey	30 %
Dark grey	10 %
Light blue	45 %
Light green	50 %
Dark green	15 %
Light yellow	65 %
Brown	25 %
Pink	50 %
Dark red	15 %

2.4 Maintenance factor:

Takes into account the depreciation in light output caused by:

- luminous flux reduction of lamps with use (depending on lamp type).
- dirt on lamps and luminaire.
- reduction of reflectance values of walls and ceiling.

Room type	Maintenance factor
Clean	0.9
Dirty	0.8



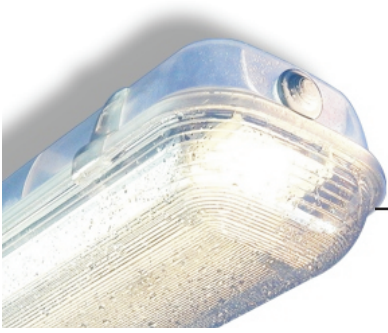

General information: Photometric calculation

3. GLARE EVALUATION FOR INTERIOR LIGHTING

To prevent glare, the luminance values in the range of the viewing angles (gamma from 45° to 85°) should not exceed specified limits.

These limits are a function of the service illuminance and the quality class of the lighting installation.

Quality class

- A = Very high
- B = High
- C = Medium
- D = Low
- E = Very Low

Recommended quality class

- A - B : offices, classrooms
- B - C : shops, medium work
- C - D : stairs, rough work
- D - E : circulation areas

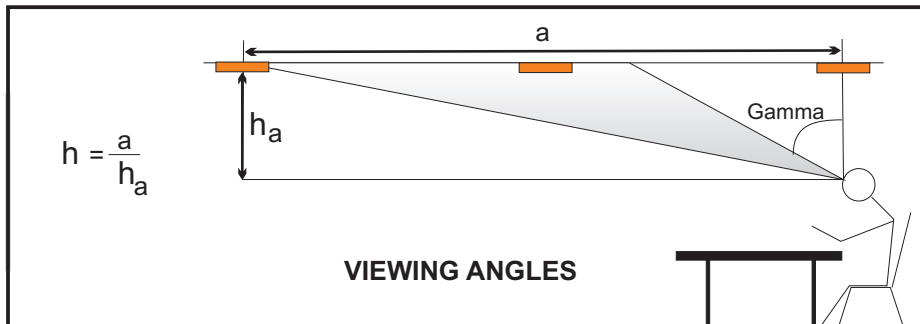

Quality class	G	Valid for service illuminance E (lux)								
		2000	1000	500	300					
A	1.15									
B	1.5		2000	1000	500	300				
C	1.85			2000	1000	500	300			
D	2.2				2000	1000	500	300		
E	2.55					2000	1000	500	300	

